

Carbon Fiber Reinforced Polymer [CFRP] Strip/Plate/Tape High Tensile Strength

**Pioneer in CFRP,
Smart & Clever for Composites**

**Structural Strengthening
Building, Bridge &
Civil Engineering
[Column, Beam & Slab]**

Timber Strengthening



Build Strip HS

Thickness & Wide Products List

- 5.00mm x 100mm x 50/m roll
- 3.00mm x 100mm x 100/m roll
- 2.00mm x 100mm x 100/m roll
- 1.40mm x 100mm x 100/m roll
- 5.00mm x 50mm x 50/m roll
- 3.00mm x 50mm x 100/m roll
- 2.00mm x 50mm x 100/m roll
- 1.40mm x 50mm x 100/m roll
- 1.40mm x 150mm x 100/m roll
- 1.40mm x 120mm x 100/m roll
- 1.40mm x 80mm x 100/m roll

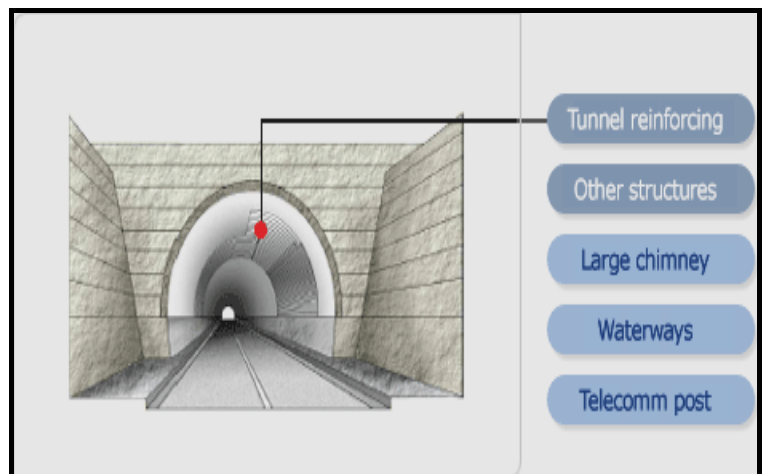
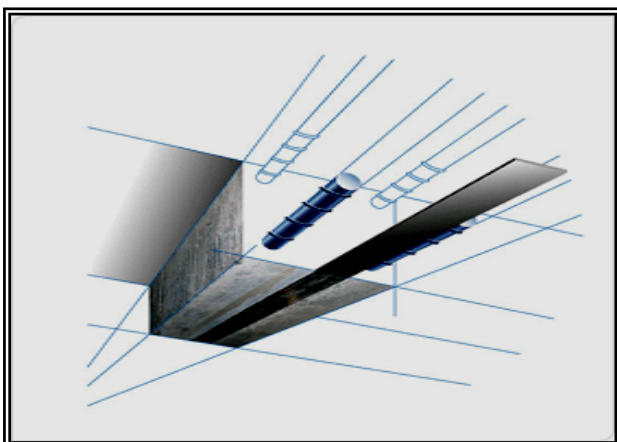



Carbon Fiber Reinforced Polymer [CFRP] High Tensile Strength [HS]

Build Strip HS

Is a type of Laminates Strip/Plate/Tape, Carbon Fiber of Putrusion Extruded Oriented, continuous carbon filaments which are held in position by a lightweight, of **Build Strip HS®** has robust handling and rapid wet-out characteristics which make it ideal for on-site strengthening of structural of buildings, bridges, beams, columns and marine structures. Additionally, **Build Strip HS®** is compatible with the special adhesive system which can be applied using a variety of wet-out/adhesive infusion techniques.

Is a composite material for the reinforcement of new and the strengthening of existing structures. The materials excellent resistance to most of forms of corrosions and the ability to dissipate energy as required in earthquake scenarios make them eminently suitable for a wide range of applications and they contribute significantly to lowering life cycle costs and increasing safety.

History Carbon Fiber

Is produced by the controlled oxidation, carbonization and graphitisation of carbon-rich organic precursors which are already in fiber form. The most common precursor is polyacrylonitrile (PAN), because it gives the best carbon fiber properties, but fibers can also be made from pitch or cellulose. Variation of the graphitisation process produces either high strength fibers (@2,600°C) or high modulus fibers (@3,000°C) with other types in between. Once formed, the carbon fiber has a surface treatment applied to improve matrix bonding and chemical sizing which serves to protect it during handling

Build Strip HS

Physical of Carbon Fiber & Matrix Epoxy

Fiber Volume Content	68% (by Weight)	[Carbon Fiber Yarn]
Binder Volume Content	32% (by Weight)	
Tensile Strength	4900 Mpa	[Toray T700, Dry Carbon Fiber Yarn Filament]
E-Modulus	230-235 Gpa	[Toray T700, Dry Carbon Fiber Yarn Filament]
Density of Carbon Fiber	1.79 g/cm ³	[Yarn Filament]
Color	Black	

Properties, Cured Laminates, [Final Performance] Carbon Fiber Reinforced Polymer

Build Strip HS

Test Method	UK Design	US Design	
Tensile Strength	ASTM D3039	>2600-3000 Mpa	377,000-435,000 psi
E-Modulus	ASTM D3039	165 Gpa.	24.00 x 10 ⁶ psi
Density Composite	ASTM D3039	1.50-1.60 g/cm ³	1.50-1.60 g/cm ³
Elongation at Break	ASTM D3039	1.70 %	1.70%
Temperature Resistance	ASTM D3039	>150°C	>150°C

Select Thickness x Wide Of Below List Products	Thickness [mm]	Width [mm]	Roll Size [Meter]	Weight [kg/Meter] or [kg/roll]	
Build Strip HS 1050	5.00	100	50	0.800	40.000
Build Strip HS 1030	3.00	100	100	0.480	48.000
Build Strip HS 1020	2.00	100	100	0.320	32.000
Build Strip HS 1014	1.40	100	100	0.224	22.400
Build Strip HS 550	5.00	50	50	0.400	20.000
Build Strip HS 530	3.00	50	100	0.240	24.000
Build Strip HS 520	2.00	50	100	0.160	16.000
Build Strip HS 514	1.40	50	100	0.112	11.200
Build Strip HS 1514	1.40	150	100	0.336	33.600
Build Strip HS 1214	1.40	120	100	0.268	26.800
Build Strip HS 814	1.40	80	100	0.180	18.000

Key Properties

- ❖ High Tensile Strength
- ❖ High Thermal Conductivity & Electrical Conductivity
- ❖ Light Weight & Transparent to X-Rays
- ❖ Excellent Fatigue & Corrosion Resistance
- ❖ Low Friction and Wear & Low Thermal Expansion
- ❖ Resistance to High Temperatures
- ❖ Good Creep and Damping Properties
- ❖ Solvent Free Working Environment & Non-Toxic

Uses

for Strengthening Reinforced Concrete Masonry, Timber Wood & Steel

Loading Increase

Increase of Supporting Live Load in Building
 Increase of Supporting Traffic Growth on Bridges
 Vibrating Machinery on Roof Slabs
 Heavy Machinery in Commercial Building

Change Design for Structural System

Dismantlement of Walls & Columns
 Dismantlement of Slabs & Beam
 Reducing of Buildings & Bridges Weight

Design or Construction Defects

Insufficient Reinforcements
 Insufficient Structural Depth

Surfaces-applied Laminates:

Laminate Type	Cross Section	Tensile Strength At Elongation 0.60%	Tensile Strength At Elongation 0.80%
Build Strip HS Modulus of elasticity 165 Gpa	[mm ²]	Theoretical Tensile Strength for the Design 1,000 N/mm ²	Theoretical Tensile Strength for the Design 1,300 N/mm ²
100mm x 5.00mm	500	500.0 kN	650.0 kN
100mm x 3.00mm	300	300.0 kN	390.0 kN
100mm x 2.00mm	200	200.0 kN	260.0 kN
100mm x 1.40mm	140	140.0 kN	182.0 kN
100mm x 1.20mm	120	120.0 kN	156.0 kN
50mm x 5.00mm	250	250.0 kN	325.0 kN
50mm x 3.00mm	150	150.0 kN	195.0 kN
50mm x 2.00mm	100	100.0 kN	130.0 kN
50mm x 1.40mm	70	70.0 kN	91.0 kN
50mm x 1.20mm	60	60.0 kN	78.0 kN
150mm x 1.40mm	210	210.0 kN	273.0 kN
150mm x 1.20mm	180	180.0 kN	234.0 kN
120mm x 1.40mm	168	168.0 kN	218.4 kN
120mm x 1.20mm	144	144.0 kN	187.2 kN



“Build Strip HS” Installed at Reinforced Beam

Application Method

Surfaces Preparation

Reinforced concrete surfaces shall be clean, structurally sound and free from foreign materials, contaminants, oily and other debris. Concrete surfaces shall not be more than 4% in moisture content and the temperature of the substrate must be at least 3°C (or) and above the current dew point temperature.

Reinforced concrete surfaces shall be clean, structurally sound and free from foreign materials, contaminants, oily and other debris. Concrete surfaces shall not more than 4% moisture content and the temperature of the substrate must be at least 3°C (or) and above the current dew point temperature.

For filling surface irregularities such as blowholes, honeycombs & etc. Please hack or cut off any unloose concrete, air blow excess dust, clean all concrete surfaces, and remain dry overnight.

Use patching method of Polymer Cementitious Mortar or pumping of High Strength Cementitious Grout. But only for concrete surfaces cracks 0.25mm, must be injected with Low Viscosity of Epoxy Resin to be filled. Using high pressure Air-Less Pump for injecting and penetration into structural crack lines, to achieve load bearing and adhesion bonding system.

Once patched, pumped or injected, before laying Carbon Fiber Laminates, all surfaces must be Hammer Tested for Polymer Cementitious Mortar, High Strength Cementitious Grout and Pull-Off Test for Cracks Lines. For achievement of strength requirement, please consult your local Engineer.

Over Head Application

Vertical Application

Applied on Over Head or Vertical Beam and Slab, either Primer, Adhesive & Resin, Waste of materials are approximately 15%.

Mixing of Primer

Use a low speed (300 to 500 rpm) electric drill fitted with a paint mixer or a wing type paddle Pour one unit of Part A & B into drum and mix for at least 3 minutes until the mix is uniform and free. (Note: Once been mixed, the Primer must be applied within 30 minutes of Pot Life).

For Uneven Surfaces

Mixing of Paste Putty

Use a low speed (300 to 500 rpm) electric drill fitted with a paint mixer or a wing type paddle. Pour one unit of Part A & B into drum and mix for at least 5 minutes until the mix is uniform and free. (Note: Once have been mixing, the Paste Putty must be applied within 60 minutes of Pot Life).

Mixing of Adhesive

Use a low speed (300 to 500 rpm) electric drill fitted with a paint mixer or a wing type paddle. Pour one unit of Part A & B into drum and mix for at least 5 minutes until the mix is uniform and free. (Note: Once have been mixing, the Paste Putty must be applied within 60 minutes of Pot Life).

Easy Installation

The easy to use Carbon Fiber system components assure fast, user friendly installation. A complete system is installed in only four (4) steps to properly prepared surfaces within appropriate working conditions.

System Recommended Use Resin Component

Epo Adhesive Strip is Epoxy Solvent Free
Two Component of Part A & Part B.
Sag Resistance until 6mm thick.
Up to 15 Mpa, Shear Strength
Up to 4 Mpa, Peel Strength
Suitable for applying on Over Head or Vertical Surfaces

1. Roll "Epo Bond Primer"

Apply **Epo Bond Primer**, applied at rate 0.20 kg/m² to 0.30 kg/m², is a low viscosity of **Primer Resin** that can be applied using a roller.
(Wait for ½ to 1 hours curing)

2. Apply "Epo Adhesive Strip"

Apply **Epo Adhesive Strip**; applied at rate 0.34 kg/meter linear to 1.5 kg/meter linear, paste adhesive is a high solid, non sag Epoxy Based or Polyurethane Based material that is applied using a Spatula Tools to level concrete surfaces.

Note: Min of Thickness of Adhesive shall be at least 0.5 mm
(Curing time: ½ hour to 4 hours depend of whether temperature)

3. Apply Carbon Fiber of "Build Strip HS®"

Within the open time of the adhesive, place immediately the **Build Strip HS®** laminates onto the adhesive surfaces, using roller or other tools to press the laminates into the adhesive until is forced out on both sides of the laminates.

Before the adhesive curing. Immediately remove surplus adhesive on both sides

Clamp The **Build Strip HS®**. The joint component should be assembled and clamped as soon as the Adhesive has been applied. An even contact pressure throughout the joint area will ensure optimum cure.

4. Apply Optional Topcoat

Where required, the Carbon Fiber high solids, high gloss, corrosion-resistant topcoat provides a protective/aesthetic outer layer. (Refer to Painting Manufacture)

Where required, the Carbon Fiber Strip Laminates to protection of Fireproofing system. Please call our technical for advice.

Note In the case of two layers and several layers of "Build Strip HS" of Carbon Fiber Strip Laminates. For multiple plies repeat steps 1, 2 and 3.

System Recommended Use Epoxy Adhesive Component

Grade of Carbon Fiber	Grade of Adhesive Recommendation	Shear Strength	Peel Strength (Cleavage)
Build Strip HS	Epo Adhesive Strip (Standard) High Shear & Peel Strength	15 N/mm ²	4 N/mm ²
Build Strip HS	Epo Adhesive Strip 335 (Slow or Fast) Ultra High Shear & Peel Strength	35 N/mm ²	12 N/mm ²
Build Strip HS	Epo Bond HT 110 (Slow or Fast) If application on High Temperature More Than > 100-130°C on Structure Reinforced	15 N/mm ²	4-6 N/mm ²

Consumptions of Epoxy Adhesive

Type of Strip Laminates	Require Approximately of Epoxy Adhesive Kg/Linear Meter	Epo Adhesive Strip 5 kg pack Coverage LM/pack	Epo Bond HT 110 5 kg pack Coverage LM/pack
All 50mm wide	0.30-0.45 kg Per linear meter	16.50 LM/pack	16.50 LM/pack
All 100mm wide	0.60-0.90 kg Per linear meter	7.50 LM/pack	7.50 LM/pack
All 120mm wide	0.75-1.05 kg Per linear meter	6.50 LM/pack	6.50 LM/pack
All 150mm wide	0.90-1.20 kg Per linear meter	5.00 LM/pack	5.00 LM/pack

Important 1: While the information and data sheet contained in this promotional literature are presented in good faith and believed to be reliable, they do not constitute a part of our terms and conditions of sales unless specifically incorporated in our Order acknowledgement. Nothing herein shall be deemed to constitute a warranty, express or implied, that said information or data sheet are correct or that the products described are merchantable or fit for a particular purpose, or that said information, data sheet or products can be used without infringing patent of third parties.

Important 2: **LAMACO Malaysia** products are not guaranteed against defective materials and manufacture & are sold subject to its standard Terms & Conditions of sale, copies of which may be obtained on request. Whilst **LAMACO Malaysia** endeavors to ensure that any advice, recommendation, specification or information is accurate and correct, it cannot- because it has no direct or continuous control over where or how its products are applied - accept any liability either directly or indirectly arising from the use of its products, whether or not in accordance any advice, specification, recommendation or information given by it.

Health & Safety Some of the components of this product may be hazardous during mixing and application. Please consult the relevant Health & Safety Data Sheets, available from **LAMACO Malaysia** on request and sent with each delivery.

LAMACO SYSTEM SDN BHD

Co. No. 1033557-M

407, Jalan Perusahaan 6, Taman Bandar Baru Mergong,
05150 Alor Setar, Kedah, Malaysia

Tel : +60-4-734 5555 Fax : +60-4-772 4444

Http : www.lamaco.com Email : info@lamaco.com

 : +60 19 4486611 +60 19 4786611



**Test Accordingly to ASTM D3039,
Cured Laminates of CFRP Polymer Matrix Composite Products
Putruction Type of CFRP Strip/Plate/Tape**

Achieving Test Result			A	B		C
Product Name	Tensile Strength [Mpa]	E-Modulus [Gpa]	Fiber Thickness mm	Fiber Width mm	Fiber Length mm	Max Tensile Load [kN]
Build Strip HS 1050 or 550	2400	140-165	5.00	10	250	120,000
Build Strip HS 1030 or 530	2400	140-165	3.00	10	250	72,000
Build Strip HS 1020 or 520	2400	140-165	2.00	10	250	48,000
Build Strip HS 1014 or 514	2400	140-165	1.40	10	250	33,600
Build Strip HS 1514 or 1214 or 814	2400	140-165	1.40	10	250	33,600
Build Strip HS 1050 or 550	2600	140-165	5.00	10	250	130,000
Build Strip HS 1030 or 530	2600	140-165	3.00	10	250	78,000
Build Strip HS 1020 or 520	2600	140-165	2.00	10	250	52,000
Build Strip HS 1014 or 514	2600	140-165	1.40	10	250	36,400
Build Strip HS 1514 or 1214 or 814	2600	140-165	1.40	10	250	36,400
Build Strip HS 1050 or 550	2800	140-165	5.00	10	250	140,000
Build Strip HS 1030 or 530	2800	140-165	3.00	10	250	84,000
Build Strip HS 1020 or 520	2800	140-165	2.00	10	250	56,000
Build Strip HS 1014 or 514	2800	140-165	1.40	10	250	39,200
Build Strip HS 1514 or 1214 or 814	2800	140-165	1.40	10	250	39,200
Build Strip HS 1050 or 550	3000	140-165	5.00	10	250	150,000
Build Strip HS 1030 or 530	3000	140-165	3.00	10	250	90,000
Build Strip HS 1020 or 520	3000	140-165	2.00	10	250	60,000
Build Strip HS 1014 or 514	3000	140-165	1.40	10	250	42,000
Build Strip HS 1514 or 1214 or 814	3000	140-165	1.40	10	250	42,000

***Tensile capacity was calculated as $\frac{C}{A \times B}$**



Specimen Sample: [Before Testing]
CFRP Strip 1.4mm x 10mm x 250mm

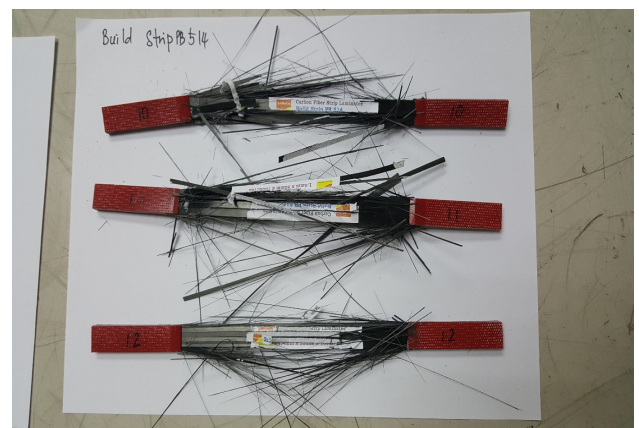

Specimen Samples: [Tested]
CFRP Strip 1.4mm x 10mm x 250mm

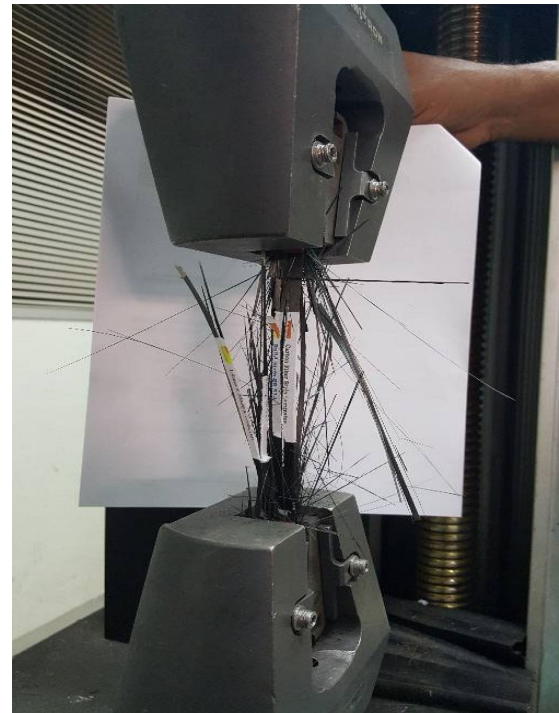
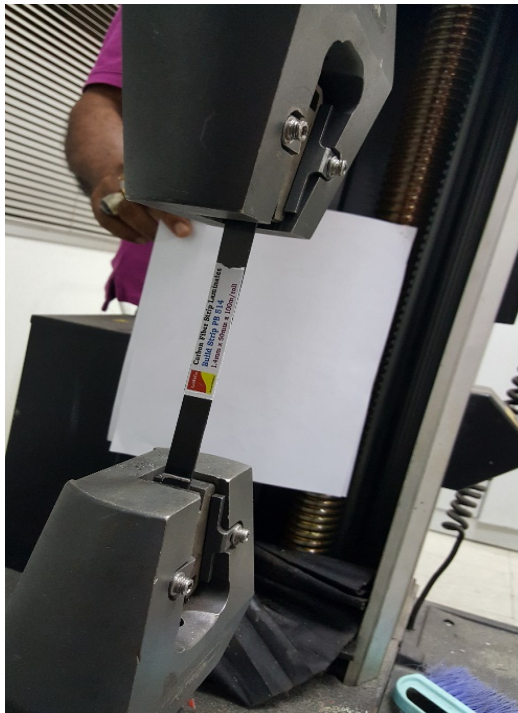

Testing Equipment, Method of Tester Installed, Once Tested the CFRP Cured Laminates Breaking

Composite tensile specimen for measurement of longitudinal properties E_L and $S_L^{(+)}$

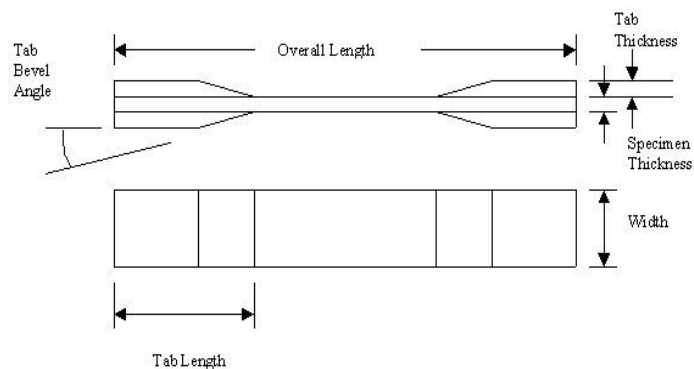

Fiber Orientation	Width, mm [in.]	Overall Length, mm [in.]	Thickness, mm [in.]	Tab Length, mm [in.]	Tab Thickness, mm [in.]	Tab Bevel Angle,°
0° unidirectional	15 [0.5]	250 [10.0]	1.0 [0.040]	56 [2.25]	1.5 [0.062]	7 or 90
90° unidirectional	25 [1.0]	175 [7.0]	2.0 [0.080]	25 [1.0]	1.5 [0.062]	90
balanced and symmetric	25 [1.0]	250 [10.0]	2.5 [0.100]	emery cloth	—	—
random-discontinuous	25 [1.0]	250 [10.0]	2.5 [0.100]	emery cloth	—	—

Specimen geometry for ASTM D3039/D3039M-08 standard tensile test. (Dimensions from ASTM D3039/D3039M-08. Copyright ASTM International. Reprinted with permission.)

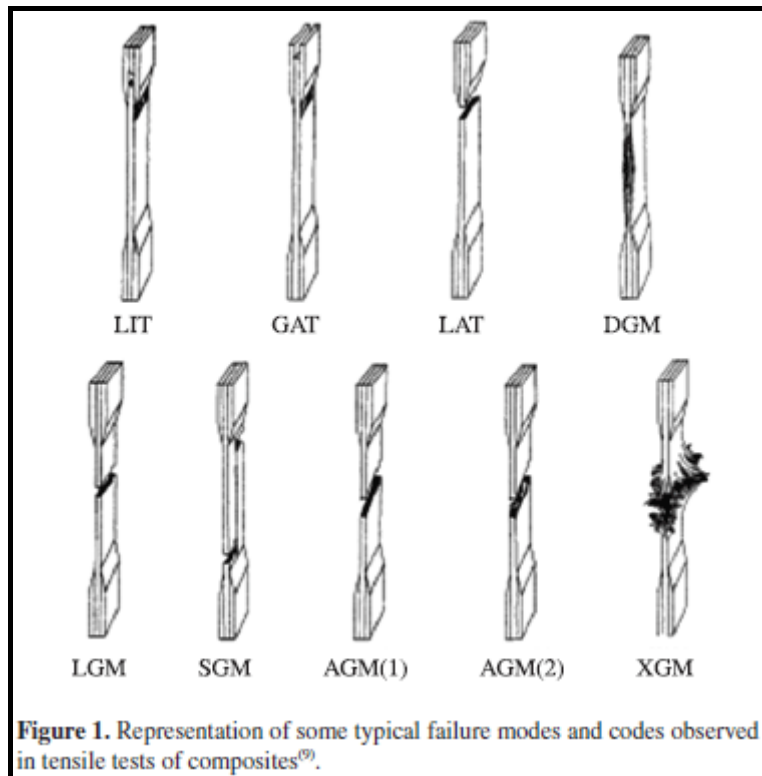
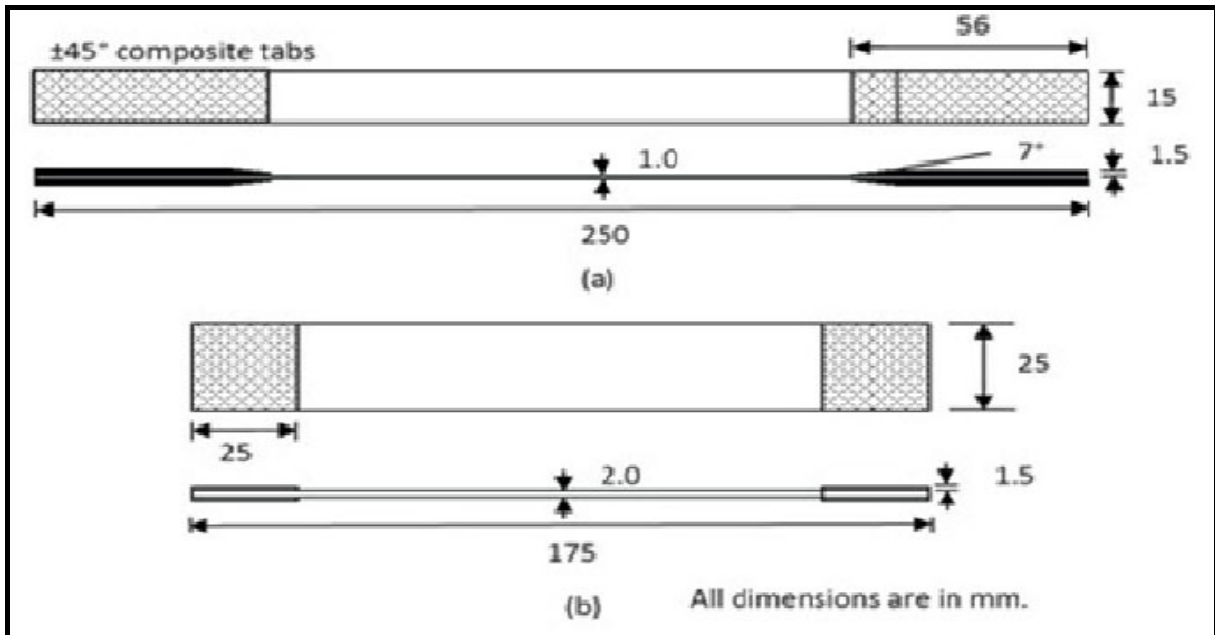

ACI 440.3R-12

Guide Test Methods for Fiber-Reinforced Polymer (FRP) Composites for Reinforcing or Strengthening Concrete and Masonry Structures

Reported by ACI Committee 440



American Concrete Institute®